

## THREE-PHASE UPS SYSTEM WITH REDUCED NUMBER OF SWITCHES

**Daniel ALBU**

Department of Electronics, University of Oradea,  
Faculty of Electrical Engineering and Information Technology,

**Abstract:** In this paper, a three-phase on-line uninterruptible power supply with reduced number of switches topology is presented. The new topology has less number of power electronic devices as well as control functions. Different operating modes of the system are investigated as well. Simulation results are presented, which show the viability of the proposed topology.

**Keywords:** three-phase on-line uninterruptible power supply, power quality, control strategy, three-phase inverter, power factor, total harmonic distortion (THD).

### 1. INTRODUCTION

The large use of non-linear loads, has increased in the last years, causing problems to the power supply systems. The harmonic currents drawn by non-linear loads from utility have contributed to reduce the power factor and to increase the total harmonic distortion (THD) in the utility input voltages. The problem increases when single-phase nonlinear loads are connected in three-phase, four-wire systems. In this case, as the phase currents are not sinusoidal, even perfectly balanced single-phase loads can result in significant neutral currents and their amplitude can exceed the amplitude of the line currents. If the non-linear loads are unbalanced, the input currents will be unbalanced in terms of fundamental and harmonic components, and a very large third component and its multiples will flow in the neutral wire. The excessive neutral currents can cause damage both in the neutral conductor and in the transformer to which it is connected. Thereby, active filter topologies have been used to compensate neutral harmonic currents. Uninterruptible power supply (UPS) systems have enabled the improvement of power source quality, providing clean and uninterruptible power to critical loads such as industrial process controls, computers, medical equipment, data communication systems, and protection against power supply disturbances or interruptions. Uninterruptible power supply provides stable supply to the system in the present or absence of the input supply. It is important for the uninterruptible power supply system to be able to take over immediately

that full load in power outage or out-of-tolerance situation to avoid any data loss, uncontrolled system shut-down or malfunctioning of the device. Commonly, the uninterruptible power supply topology can be classified as off-line uninterruptible power supply, line interactive uninterruptible power supply and on-line uninterruptible power supply. While the on-line uninterruptible power supply systems are widely recognized as the superior topology in performance, power conditioning, and load protection, it should be mentioned that they use a large number of switches and as a consequence have a high cost. This is especially true for three-phase uninterruptible power supply systems. Typical three-phase on-line uninterruptible power supply systems are shown in Figure 1 and Figure 2.

The uninterruptible power supply system from Figure 1,a has at its front-end a three-phase controlled AC/DC rectifier consisting of input inductors RL<sub>a</sub>, RL<sub>b</sub>, and RL<sub>c</sub>, and six switches: S1 to S6. It is controlled to charge the DC capacitor to a level sufficient for proper operation of the back-end inverter. At the same time, (Figure 1,b), it can provide power factor correction (PFC). The power factor correction control is of boost type, so the uninterruptible power supply system can work in the normal operation mode even when the input AC voltage is considerably lower than the nominal value. The bidirectional DC/DC converter is the usual charger/discharger.

The DC/AC inverter consists of six switches S7 to S12. It is controlled in a high-frequency PWM pattern to give high-quality

sinusoidal output voltage with a low total harmonic distortion.

An isolation transformer is required for safety. The static switch is used to transfer the load directly to the AC line in case of uninterruptible power supply system failure or if maintenance is required. It can also be used to support fault clearance.

In the three-phase on-line uninterruptible power supply system from Figure 2, a combination of an uncontrolled three-phase rectifier and a boost DC/DC converter replaces the controlled front-end rectifier.

The uncontrolled rectifier consists of six diodes: D1 to D6. Its purpose is to rectify the AC voltage. The boost converter consists of a DC inductor L1, switch S7, and diode D7. Its purpose is to maintain the input current sinusoidal and in phase with the input AC voltages, providing in this way unity power factor. The rest of the three-phase on-line uninterruptible power supply system is the same as that from Figure 1.

**2. SYSTEM DESCRIPTION**

The new three-phase on-line uninterruptible power supply system, shown in Figure 3, constitutes a front-end uncontrolled AC/DC rectifier, followed by a power factor correction boost converter, a

half-bridge type DC/AC inverter with an isolation transformer, a battery charger, a battery bank, a transfer switch St in the form of thyristor, and a bypass static switch. The uncontrolled rectifier consists of six diodes: D1 to D6. It rectifies the AC voltage, while the boost converter at the back-end of the rectifier is in charge of providing power factor correction. It consists of inductor L1, switch S5, and diode D7.

The DC/AC inverter consists of a split DC bus, and four switches S1, S2, S3, and S4, as well as an isolation transformer. It operates in a high-frequency SPWM pattern in order to provide high-quality sinusoidal output voltage.

The battery charger is a DC/DC buck converter, which consists of switch S6, diode D8, and inductor Ldc. Its purpose is to step down the high DC bus voltage to low battery voltage, thus controlling the charge of the battery bank.

The transfer switch St is used to transfer the input power source from the AC line to the battery. The bypass static switch is used in case of failure or if maintenance is required. In order to ensure unnoticeable transfer from normal to bypass mode and vice versa, the inverter output voltage must be in phase with the AC line voltage.

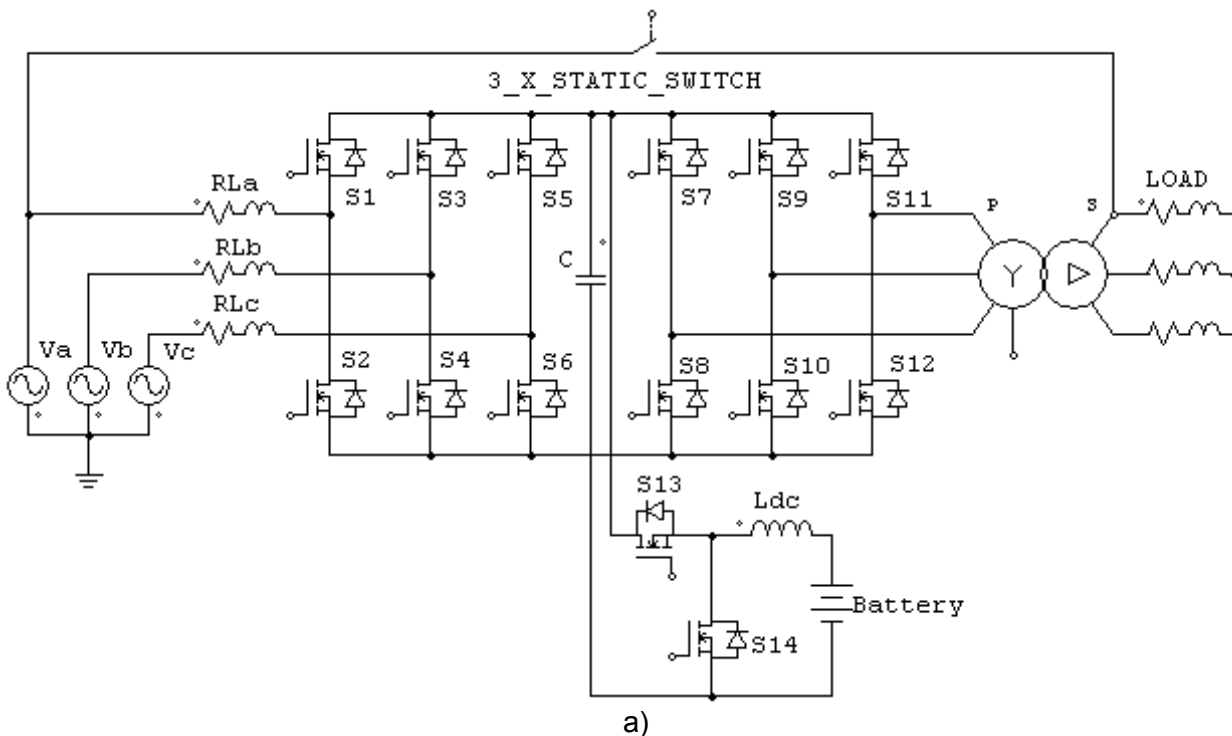

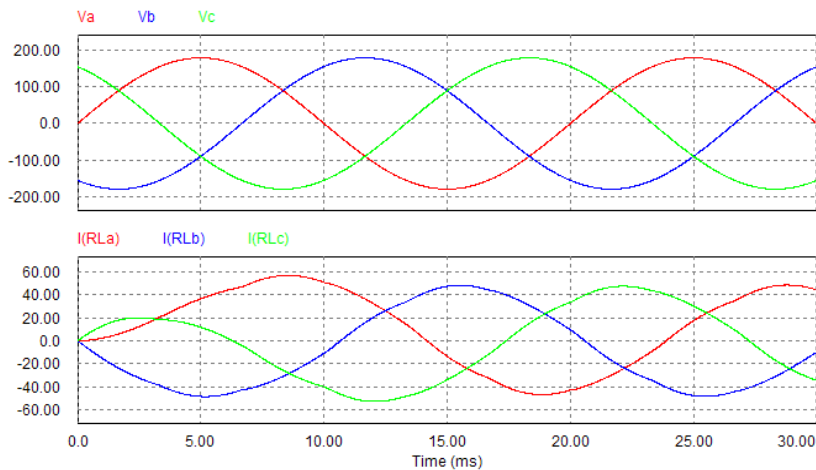

b)

Figure 1. a) Three-phase on-line UPS system with a controlled rectifier, b) Input phase voltages  $V_a$ ,  $V_b$ ,  $V_c$ , and input phase currents  $I(RL_a)$ ,  $I(RL_b)$ , and  $I(RL_c)$

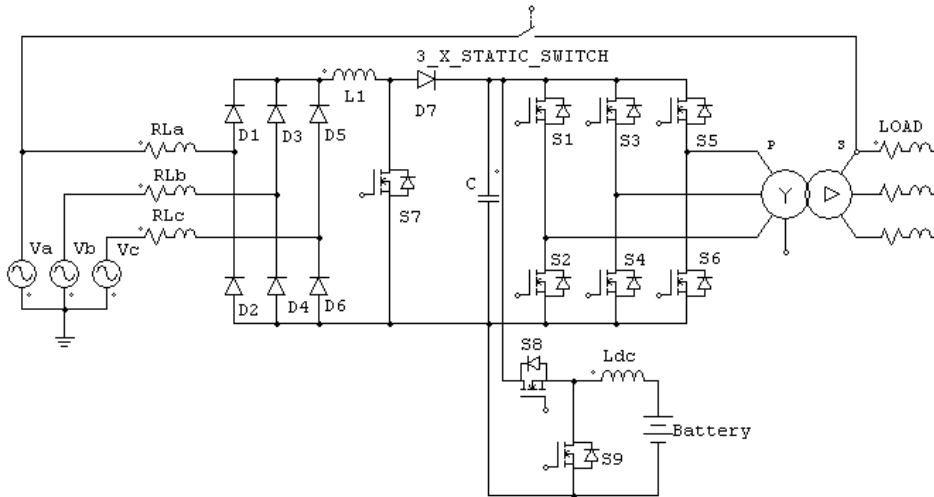

a)

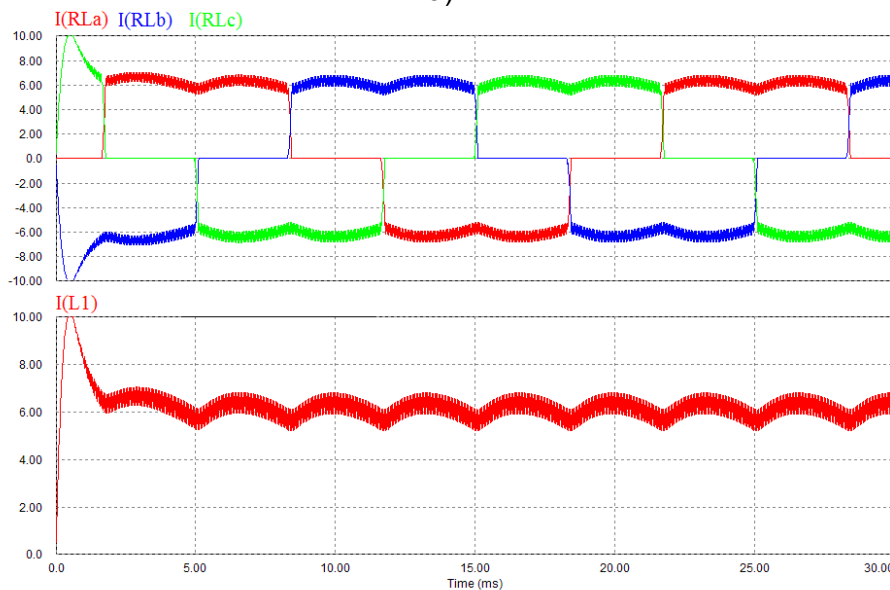

b)

Figure 2. a) Three-phase on-line UPS system with an uncontrolled rectifier, b) Current through inductor  $L_1$  and input phase currents  $I(RL_a)$ ,  $I(RL_b)$ , and  $I(RL_c)$

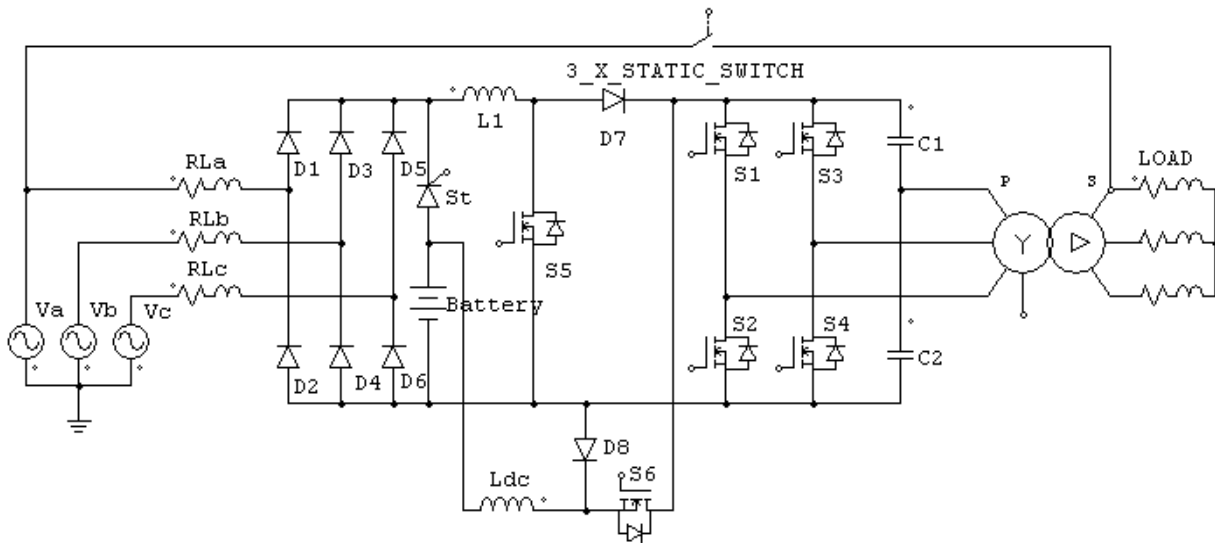

Figure 3. Three-phase on-line UPS system reduced number of switches.

### 3. PRINCIPLES OF OPERATION

The proposed UPS system has three operating modes: normal mode, stored energy mode, and bypass mode. In the normal mode of operation, the input AC voltage is within the permissible tolerance range. The power is passed from the AC/DC rectifier to the DC/AC inverter and the load is continuously supplied with high-quality AC power. The DC/DC buck converter charges the battery and maintains it at 100 % state of charge. The transfer switch *St* is off. The three-phase rectifier works in the following way. The three-phase uncontrolled rectifier followed by a power factor correction boost converter. When switch *S5* is turned on, the input line voltage is applied across the boost inductor *L1* and the corresponding currents in the phases start increasing / decreasing according to:

$$V_m \cdot \sin(\omega t) = L_1 \cdot \frac{di}{dt} \quad (1)$$

When switch *S5* is turned off, the energy stored in the boost inductor *L1* is transferred through diode *D7* to the DC-link charging capacitors *C1* and *C2*. Since the current shaping converter is of a boost type, the DC-link bus voltage is always larger than the maximum amplitude value of the input voltage and as a result the voltage across the boost inductor *L1* is negative. The input phase currents start decreasing / increasing according to:

$$V_m \cdot \sin(\omega t) = L_1 \cdot \frac{di}{dt} + V_{dc} \quad (2)$$

The input phase currents change with a rate proportional to the instantaneous value of their corresponding input phase voltages, and their peak values are also proportional to the average value of their corresponding phase voltages. Since these voltages are sinusoidal, then the peak currents will also be sinusoidal. Keeping in mind that the rectifier works in discontinuous conduction mode, the average values of the input currents will be sinusoidal. In summary, the input currents consist of high-frequency harmonics and low-frequency fundamental harmonics at 50 Hz. Removing the high-frequency harmonics is easily achievable with a small electromagnetic interference (EMI) filter. The current shaping switch *S5* operates at constant frequency. The duty cycle varies with the load to ensure a tightly regulated DC-link bus voltage. The DC/AC three-phase inverter consists of a split DC-link capacitor bus and two MOSFET legs, with switches *S3*, *S4* and *S5*, *S6*. It is controlled in a high frequency PWM pattern to yield a high-quality sinusoidal output voltage with low THD. A three-phase AC voltage system is obtained from the four switch inverter by using sinusoidal PWM control strategy where the control signals for the two legs are 120° phase shifted from each other.

The control strategy for the three-phase inverter uses two control loops for each inverter leg: one outer voltage loop and one inner current loop. The outer control loop

uses the output line voltage as a feedback signal, which is compared with a reference signal. The two reference signals for the two legs are phase shifted 120° from each other. The error is compensated by a PI integrator to achieve stable output voltage under steady state operation. This error is also used as a reference signal for the inner current regulator loop, which uses the output inductor current as a feedback signal. The minor current loop is much faster than the outer voltage loop, and improves the dynamic response of the inverter. As a result, the output voltage has a very high quality even with a highly nonlinear load. In the stored-energy mode of operation, when the input AC voltage is beyond the permissible tolerance range, switch  $S_t$  is turned on, transferring the input from the AC line to the battery bank. The boost converter used in the normal operation mode for current shaping is now used for boosting the low battery voltage to high DC-link bus voltage. When switch  $S_5$  is turned on, the voltage across inductor  $L_1$  is positive and the current through it starts to increase. When switch  $S_5$  is turned off, the current through inductor  $L_1$  follows the path  $V_{bat}-L_1-D_7-C_1-C_2-V_{bat}$  and charges DC-link capacitors  $C_1$  and  $C_2$ . The low battery voltage is a function of the battery voltage and the duty ratio of switch  $S_5$  is:

$$V_{dc} = \frac{V_{bat}}{1-D} \quad (3)$$

#### 4. SIMULATION RESULTS

Various computer simulations have been carried out, using PSIM simulation software, to help design the control for the new UPS system. The simulation results for normal mode of operation for the proposed UPS system are shown in Figure 4. The input phase currents  $I(RLa)$ ,  $I(RLb)$ , and  $I(RLc)$  are sine waves in phase with the corresponding input AC voltages  $V_a$ ,  $V_b$ , and  $V_c$ , resulting in power factor very close to unity. The DC-link bus voltage is regulated at 700 V or 350 V for each capacitor  $C_1$  and  $C_2$ . At the same time, the battery charger steps down the high DC-link bus voltage to the low battery charging voltage. The back-end DC/AC inverter continuously supplies the load with a high-quality three-phase voltage.

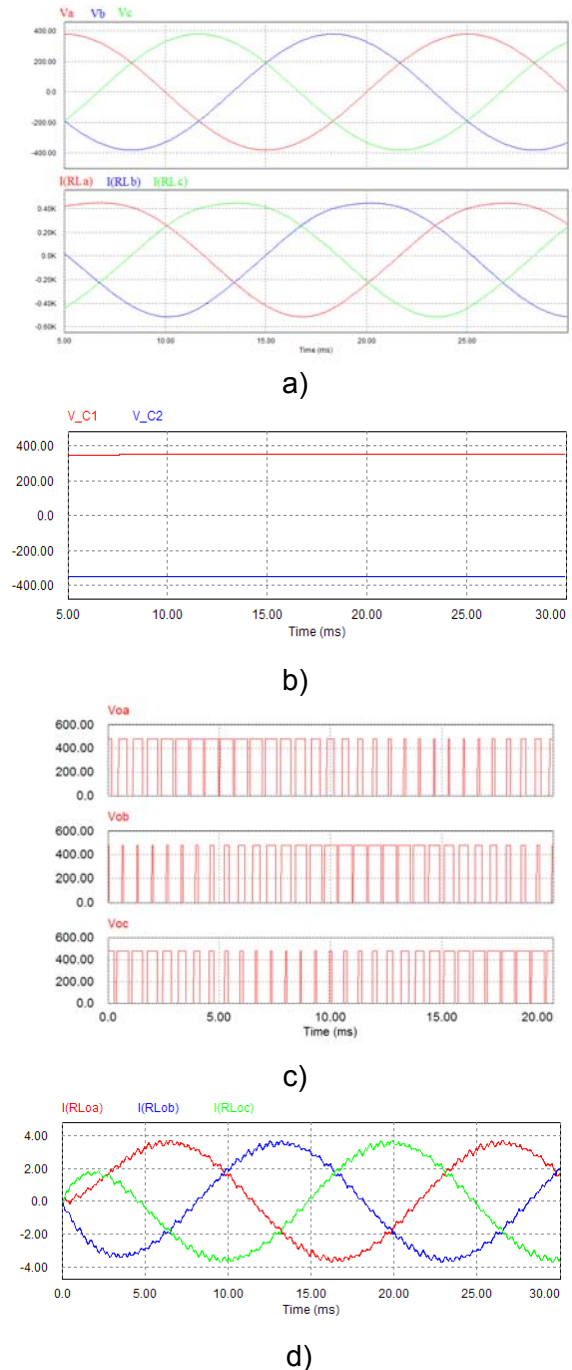

**Figure 4. Simulation results for normal mode of operation: a) Input phase voltages  $V_a$ ,  $V_b$ ,  $V_c$ , and input phase currents  $I(RLa)$ ,  $I(RLb)$ , and  $I(RLc)$ , b) DC-link voltages for each capacitor  $C_1$  and  $C_2$ , c) output phase voltages  $V_{oa}$ ,  $V_{ob}$ , and  $V_{oc}$ , d) load phase currents  $I(RLoa)$ ,  $I(RLob)$ , and  $I(RLoc)$ .**

#### 5. CONCLUSIONS

The proposed three-phase on-line UPS system has many performance features characteristic only for the high-end quality truly state-of-the-art UPS systems, such as:

- a) High-quality sinusoidal output voltages even with highly nonlinear and non symmetrical loads.
- b) Unity input power factor.
- c) Excellent transient characteristics and stability.
- d) Small weight, size, and cost.

By making use of the fact that the uncontrolled rectifier at the front-end of the UPS system is followed by a boost DC/DC converter for PFC purposes, the conventional boost converter, used for boosting the low battery voltage, has been eliminated, which results in a substantial cost, weight, and size savings without any compromise in the performance.

Additional cost savings have been realized by using a four-switch DC/AC inverter topology instead of the conventional six-switch inverter topology. In sum, the proposed three-phase on-line UPS system with its compactness, low cost, and excellent performance is a strong candidate for the optimal low-cost UPS system for low to middle power applications.

## REFERENCES

- [1] KAMRAN, F., HABTLER T.: "A Novel on-line UPS with Universal Filtering Capabilities", Proceedings of the 26<sup>th</sup> Power Electronics Specialist Conference, PESC, 1995, p. 500-506.
- [2] NED MOHAN, TORE M. UNDELAND, WILLIAM P. ROBBINS: "Power Electronics", John Wiley & Sons, Inc.
- [3] R. CHAUPRADE: "Inverters for Uninterruptible Power Supplies", I.E.E.E. Transaction on Power Electronics, 1977.
- [4] VIOREL POPESCU: "Surse de alimentare neîntreruptibile", Editura de Vest, Timișoara, 2004
- [5] VIOREL POPESCU: "Convertoare electronice de putere", Editura de Vest, Timișoara 1999
- [6] ROBERT W. ERICKSON; DRAGAN MAKSIMOVIC: "Fundamentals of Power Electronics", Kluwer Academic Publishers, 2001

Daniel ALBU, Department of Electronics, University of Oradea, Faculty of Electrical Engineering and Information Technology, Postal address 410087, Oradea, Bihor, Romania, 1, Universitatii street, E-Mail: [dalbu@uoradea.ro](mailto:dalbu@uoradea.ro)